

TECHNICAL SPECIFICATIONS - SCAPREDICT

27/11/2025

HDSN provides a **dedicated HMI solution** for real-time monitoring of up to **512 E-PREDICT with dry contacts**, using **digital input modules** that communicate via the **Modbus TCP/IP protocol**.

Key Features:

- **View the status of each connected E-PREDICT in real time.**
→ Monitor digital inputs states of the Modbus module.
- **Trigger external alert system**
→ Automatically activate external alarms (e.g., sounders or flash indicators) in the event of:
 - ✓ Abnormal overheating detection inside an electrical cabinet
 - ✓ Power cut at E-PREDICT
 - ✓ E-PREDICT not operational

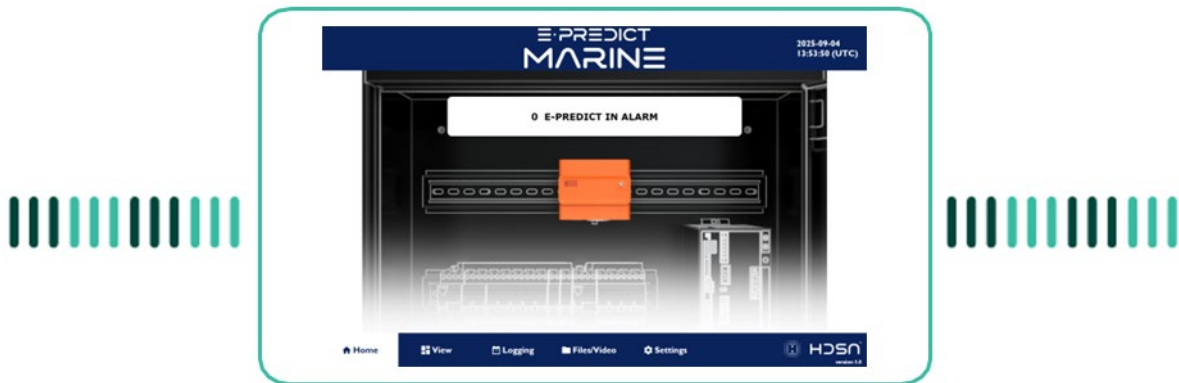

E-PREDICT SUPERVISION CONTROL ACTION V4.0

Table of Contents

1.	USE OF THE HMI.....	3
	START SCREEN.....	3
	HOME SCREEN	3
	VIEW SCREEN.....	3
	LOGGING SCREEN.....	9
	FILES/VIDEO SCREEN	9
	SETTINGS SCREEN.....	10
	PERIODIC INSPECTION OF E-PREDICT	14
2.	MODBUS COMMUNICATION TABLES	17
	COIL REGISTERS	17
	HOLDING REGISTERS.....	17
	DISCRETE INPUT	17
3.	HARDWARE.....	18
4.	MAINTENANCE.....	20

E-PREDICT SUPERVISION CONTROL ACTION V4.0

1. USE OF THE HMI

START SCREEN

HDSN can pre-configure the screen with the information from the implantation study carried out beforehand.

HOME SCREEN

The home screen displays the number of devices currently in alarm. If this number exceeds 0, an alarm flash/siren is triggered, and an alarm message is shown on the screen. The HMI box indicator is also activated.

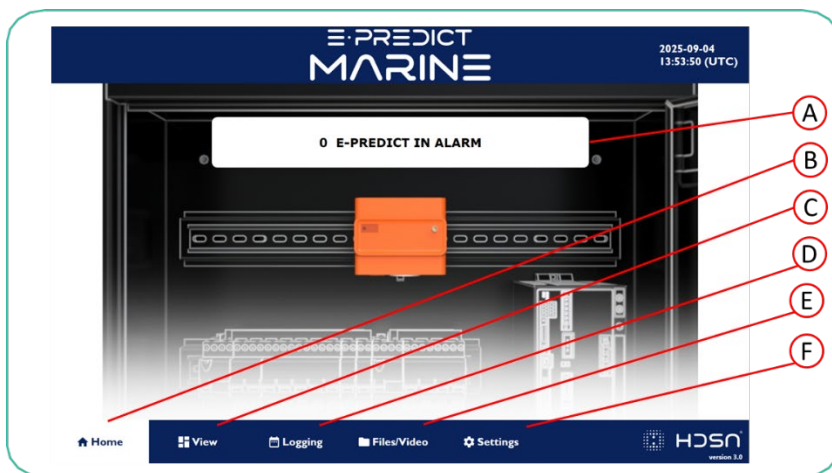

- A Number of devices in alarm
- B Access to HOME screen
- C Access to VIEW screen
- D Access to LOGGING screen
- E Access to FILE/VIDEO screen
- F Access to SETTINGS screen

VIEW SCREEN

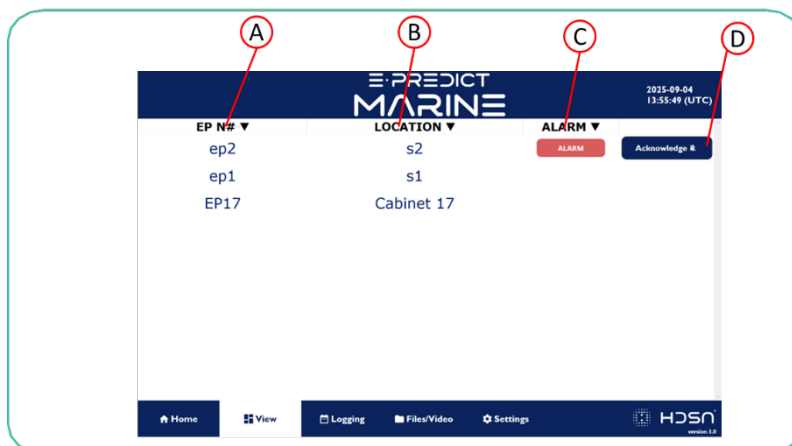

- A Name of E-PREDICT
- B Editable location field
- C Alarm indicator
- D Acknowledge button

E-PREDICT SUPERVISION CONTROL ACTION V4.0

The display screen displays real-time status of the E-PREDICT Dry Contacts connected to the digital inputs of the input module (CT-121F). Each input module includes 16 digital inputs, allowing it to support up to 16 E-PREDICT devices. Users can configure the system to manage up to 512 inputs in total. On the same page, if an alarm is triggered, an acknowledge button appears.

Important note: *The alarm disappears if it has been acknowledged on the HMI **AND** resolved on the E-PREDICT side (restart).*

LED Status Indicators

Each input is associated with an LED indicator showing one of the following states:

No indicator: The corresponding E-PREDICT device is operating normally, and no alarm is active.

● **Blinking RED:** An alarm (overheating inside the electrical cabinet) is active, and it has not yet been acknowledged via the HMI. **The E-PREDICT LED is RED (abnormal overheating in the electrical cabinet).**

● **Fixed RED:** An alarm (overheating inside the electrical cabinet) is always active and has been acknowledged on the HMI. This status will disappear once the fault in the electrical cabinet has been resolved and the device will be restarted. **The E-PREDICT LED is RED (abnormal overheating in the electrical cabinet).**

● **Blinking ORANGE:** An alert (E-PREDICT is not operational) is active, and it has not yet been acknowledged via the HMI. **The E-PREDICT LED is FIXED ORANGE (E-PREDICT not operational) or BLINKING ORANGE (E-PREDICT fan does not rotate properly).**

● **Fixed ORANGE:** An alert (E-PREDICT is not operational) is always active but has been acknowledged on the HMI. This status will disappear once the issue on the device has been resolved. **The E-PREDICT LED is FIXED ORANGE (E-PREDICT not operational) or BLINKING ORANGE (E-PREDICT fan does not rotate properly).**

● **Blinking GRAY:** A power loss on E-PREDICT has been detected. The E-PREDICT LED is OFF (device not powered).

● **Fixed YELLOW:** The input is currently inhibited. This status can be manually set by the user which is useful during maintenance or operations that may generate environmental disturbances and lead to false alarms.

E-PREDICT SUPERVISION CONTROL ACTION V4.0

Temporarily inhibited an input (yellow status, see above):

To inhibit an entry (corresponding to one E-PREDICT):

- VIEW page: click on the line to be inhibit (see SETTINGS SCREEN). A popup appears where you can change the name, location and detection of the alarm (enable/disable for up to 24 hours for the normal mode).

Module : 0, I/O : DI1

Device Name:
EP1

Device Location:
TGBT1

Disable alarm for :
Never

SAVE AND CLOSE

- Only Chief Engineer / Admin mode can inhibit the line for undefined. To enable Chief Engineer / Admin mode, go to the "Settings" page and enter the password.

ALARM MANAGEMENT PROCEDURE – E-PREDICT

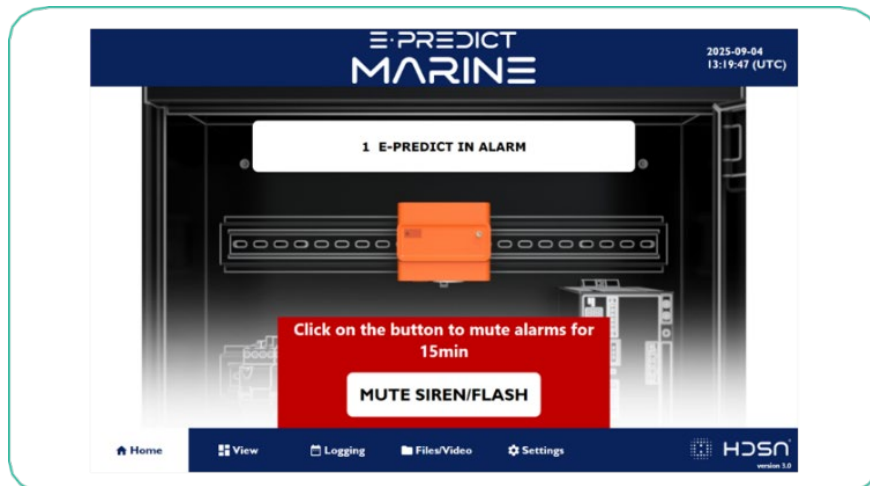

Alarm acknowledgement steps

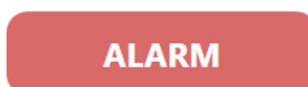

E-PREDICT SUPERVISION CONTROL ACTION V4.0

1. Temporarily Disable the Siren/Flash

→ The alarm siren/flash signal from the HMI can be shut down for 15 minutes by clicking on MUTE SIREN/FLASH button.

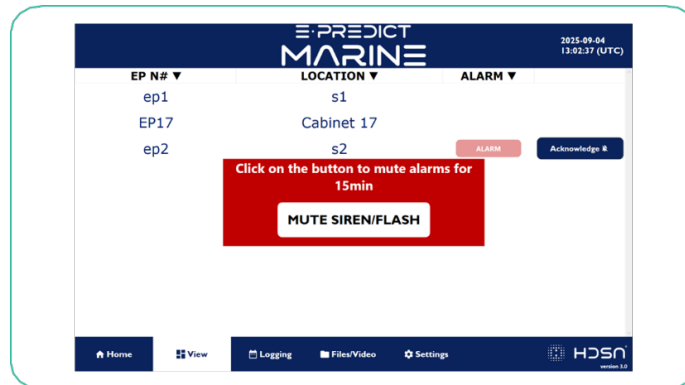

2. Ack the alarm on the HMI

Click on the “Acknowledge” button for the relevant E-PREDICT.

→ Give your operator's position and click on Confirm button.

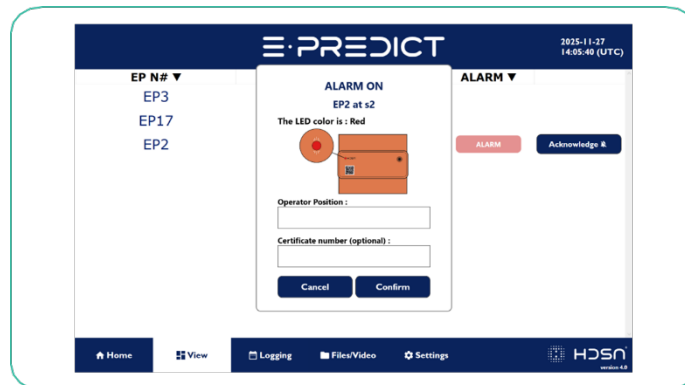

3. Follow HMI Guidance

→ The HMI provides troubleshooting advice and steps to assist in handling the alarm.

The HMI displays a questionnaire:

- Was a thermal camera used?
- Have you fixed an issue?
- What was the issue?
- Did you restart E-PREDICT? (mandatory)

E-PREDICT SUPERVISION CONTROL ACTION V4.0

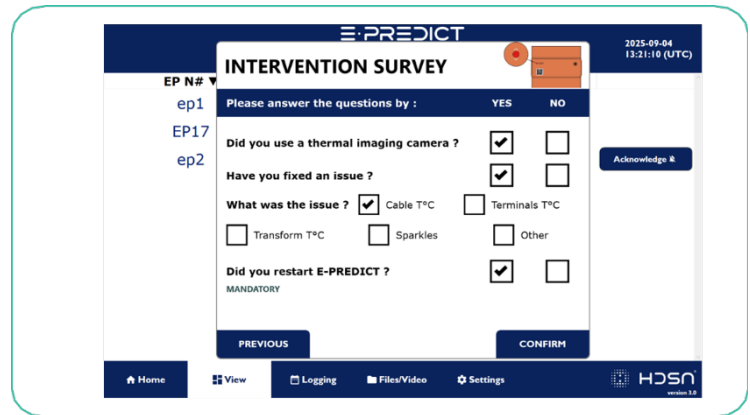

4. Diagnose and Resolve the Issue

→ Identify the cause of the alarm and carry out corrective actions on the installation.

5. Confirm Resolution

→ Once resolved, the E-PREDICT LED should turn green (after E-PREDICT restart), confirming a return to normal operation. If the LED does not return to green, contact HDSN technical support (sav@hdsn.fr).

⚠ Important Note: If the alarm is disable but the issue remains unresolved, the alarm status will stay active.

E-PREDICT SUPERVISION CONTROL ACTION V4.0

Alert acknowledgment steps



1. Temporarily Disable the Siren/Flash

→ The Alert siren/flash signal from the HMI can be shut down for 24 hours by clicking on MUTE SIREN/FLASH button.

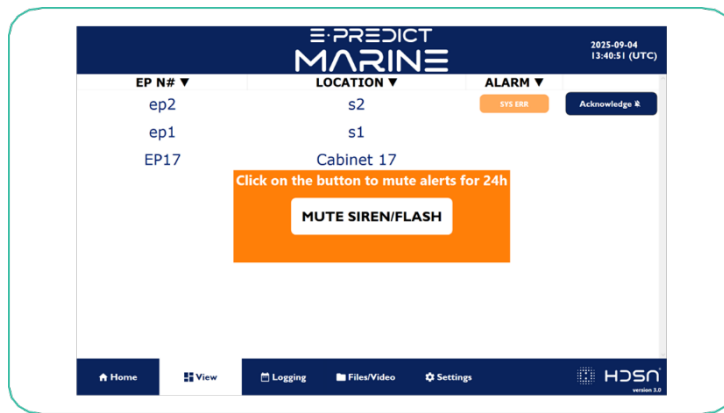

2. Ack the alert on the HMI

→ The procedure is the same as for the alarm. Each alert and acknowledgement are logged.

⚠ Important Note: If the alert is disable but the issue remains unresolved, the alert status will stay active.

Specific case: power loss on E-PREDICT



There is no acknowledgement for a power failure on a product. The HMI will automatically acknowledge a product off alert as soon as power is restored.

E-PREDICT SUPERVISION CONTROL ACTION V4.0

LOGGING SCREEN

The history screen displays all alarms and their acknowledgements. The date and time of the event are indicated. The operator's name is indicated for each acknowledgement.

Data can be exported (.csv) by plugging a USB key into the Panel PC. By clicking on the “Export Data” button, the data will be automatically saved to an external disk connected to the Panel PC.

Date	Hour	Type	Message
2025-09-04	15:21:20	Acknowledge	ACK on ep2 (MO DIO) with LED RED by ENGINEER
2025-09-04	15:21:20	Survey	DIO_MO_Result : RED LED,True,True,Issue : Cable T°C ,True
2025-09-04	15:20:11	Activity	Alarm output disable for 15min
2025-09-04	15:02:22	E-PREDICT Status	Alarm on ep2 (MO DIO) : abnormal overheating in the cabinet
2025-09-04	15:01:27	Activity	Exit Mode
2025-09-04	15:01:22	Activity	Client Information has been change
2025-09-04	15:01:17	Activity	IHM logo has been deleted
2025-09-04	15:01:11	Activity	Log in as Super Admin
2025-09-04	15:00:44	Activity	Exit Mode
2025-09-04	15:00:35	Activity	Client Information has been change
2025-09-04	15:00:33	Activity	The inputs have been modified correctly.
2025-09-04	14:57:31	Activity	Log in as Chief Engineer
2025-09-04	14:57:16	Activity	Periodic inspection reminder pop-up closed
2025-09-04	14:57:12	System	The HMI has started
2025-09-04	14:50:47	System	The HMI has started
2025-09-04	14:42:42	Activity	IHM logo has been change
2025-09-04	14:42:41	Activity	IHM logo has been deleted
2025-09-04	14:42:38	Activity	IHM logo has been change

A Date and time of event
B Event Type
C Data export button
D Event message

FILES/VIDEO SCREEN

The Files/Video tab contains all the useful documents and media related to E-PREDICT. Users will find a video presentation of the equipment, its technical datasheet, and detailed procedures for the periodic and functional tests to be carried out to ensure proper system operation.

Video: E-Predict_EN_ST.mp4 Display Video TechSpec-E-PREDICT-INDUSTRY V3 (FR).pdf Display PDF

E-PREDICT
SPECTRE
E-PREDICT-INDUSTRY (Def_HDS-SPC05E-FR)

CE DOCUMENT CONCERNE LE PRODUIT E-PREDICT-INDUSTRY V3 (MONTAGE).
 POUR VÉRIFIER LA VERSION DE VOTRE PRODUIT, VOUS LEZ SCANNER LE QR CODE CI-DESSUS SUR LA
 FACE AVANT DU E-PREDICT AVEC VOTRE APPAREIL PHOTO DE VOTRE SMARTPHONE.

UN QR CODE VOUS PERMET DE CONSULTER LA VERSION DE VOTRE PRODUIT.
 E-PREDICT-INDUSTRY V3 - main v3 (FR) dans son fichier document

HDSN

E-PREDICT SUPERVISION CONTROL ACTION V4.0

SETTINGS SCREEN

The settings screen centralizes both customer information and interface configuration settings. The Chief Engineer / Admin mode password is **112233**.

The user can modify the settings by logging on in Chief Engineer / Admin mode:

- **Chief Engineer / Admin mode (Password: 112233)**

The Chief Engineer / Admin can view and modify customer information and some HMI configuration parameters. The mode status is displayed at the top of the screen, in flashing yellow, to clearly indicate the current access level.

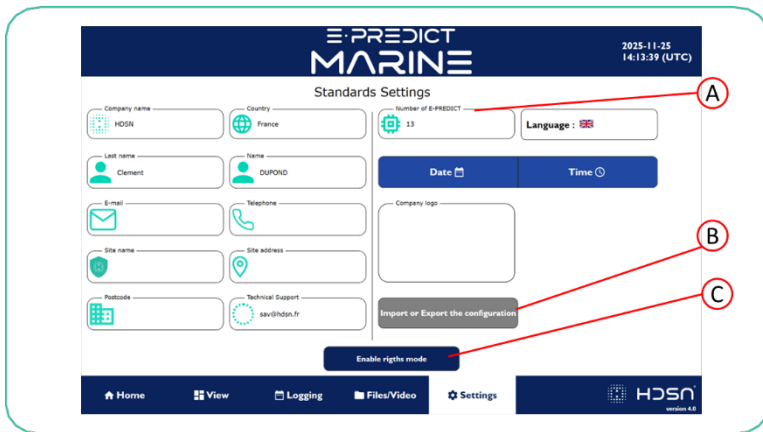

A. Customer information

Fill in the following fields with the relevant information:

- Company name: Indicate the social reason of the company.

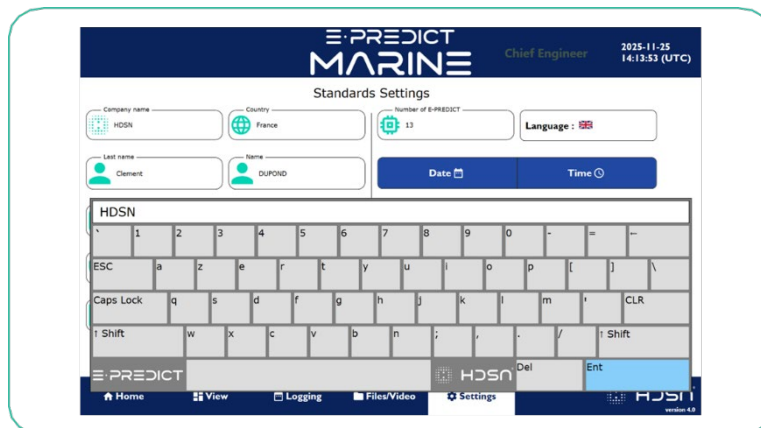

E-PREDICT SUPERVISION CONTROL ACTION V4.0

- Country: (if necessary) Enter the country where the installation is based.

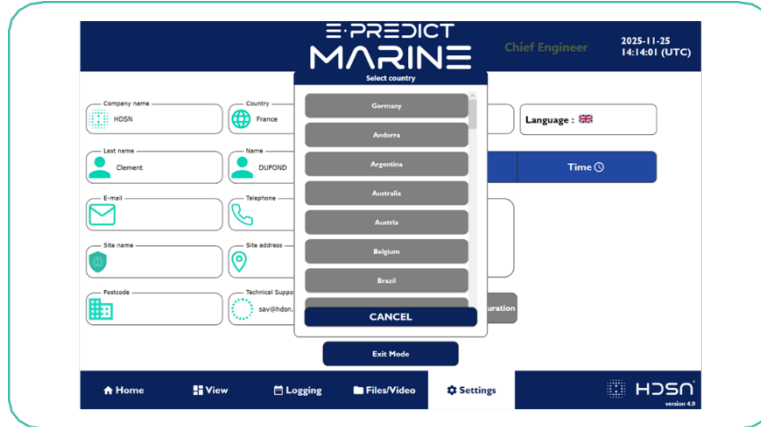

All the information below must be filled in:

- Last Name: Enter the supervisor last name.
- Name: Enter the supervisor name.
- Email: Enter a valid email address for correspondence.
- Telephone number: Enter the telephone number.
- Site name: Specify the site, vessel or facility where the system is located.
- Company address: (if necessary) Enter the company's full address.
- Zip code: (if necessary) Enter the zip code corresponding to the address.
- Technical Support: Enter a valid email address for technical support

B. HMI settings

- Date: Update date using the "Date" button.

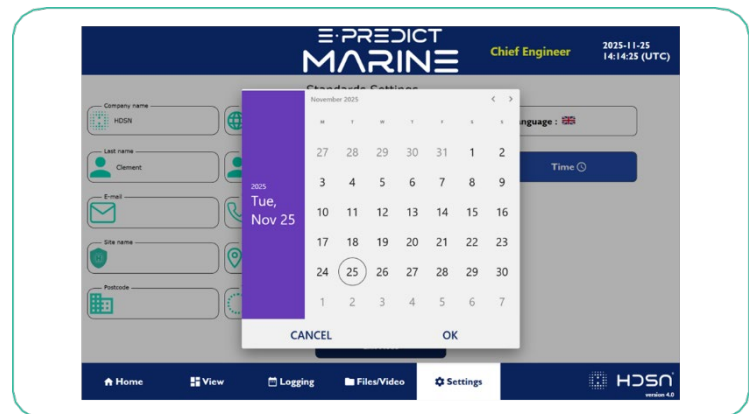
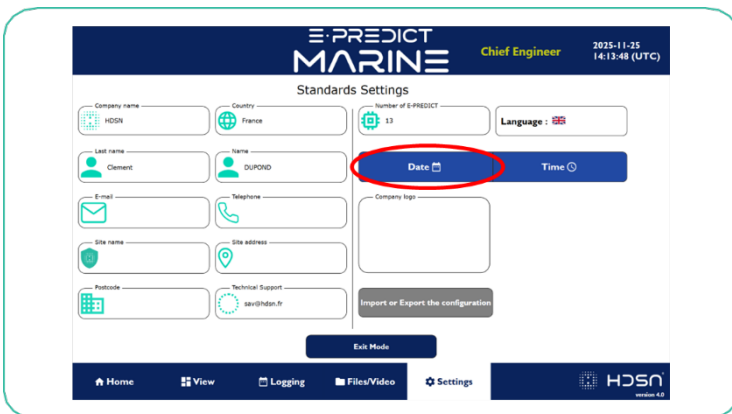

E-PREDICT SUPERVISION CONTROL ACTION V4.0

- Time: Update time using the “Time” button.

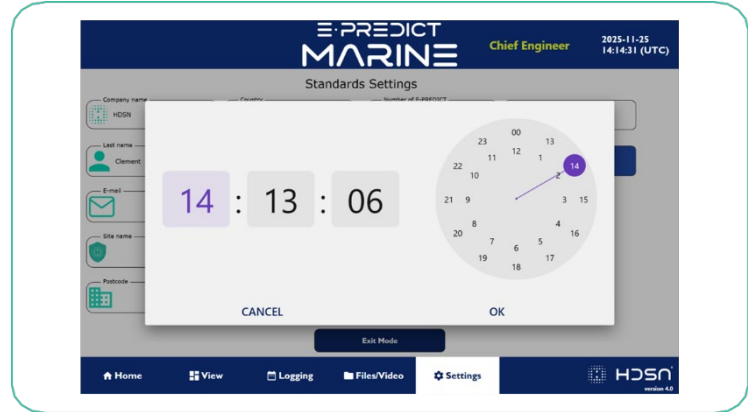
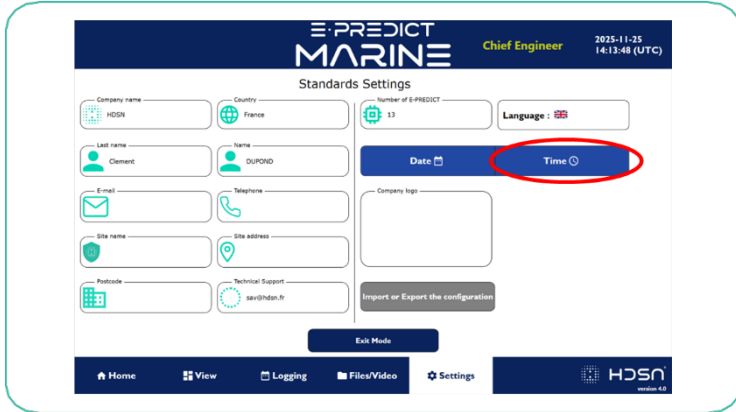

- Company logo: You can add your company logo to the Company Logo box. To do this, save your logo image as “logo_image” on a USB key, plug it into the HMI, then click on the Company Logo box: the logo will be displayed automatically.
(Note: If the logo is white, it will be invisible to the eye because the background is white.)

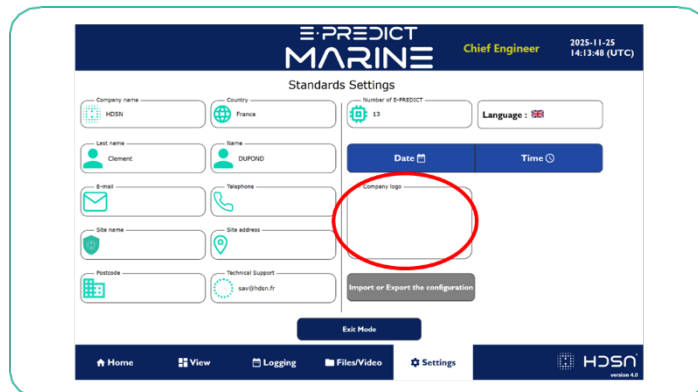

- Import/Export HMI config: You can import or export an HMI configuration using a USB key.
Warning: Doing this will delete the current configuration.

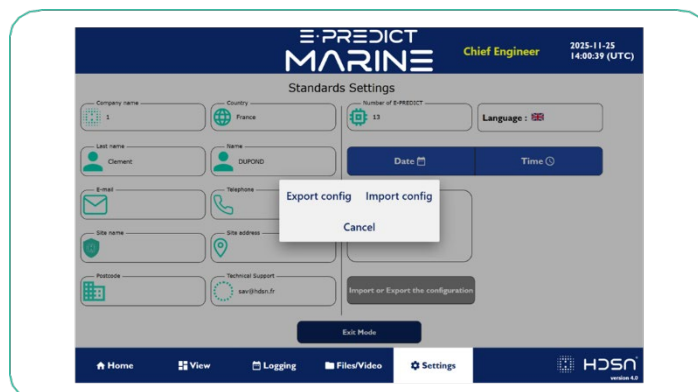

E-PREDICT SUPERVISION CONTROL ACTION V4.0

- Number of E-PREDICT: You can change the number of E-PREDICTs connected on the HMI by clicking on the “Number of E-PREDICT” field. A window appears with a list of input backplane and input card modules, allowing you to enable or disable digital input.

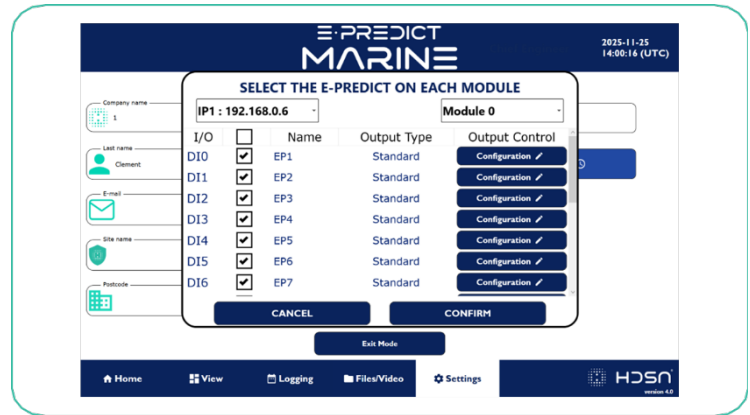
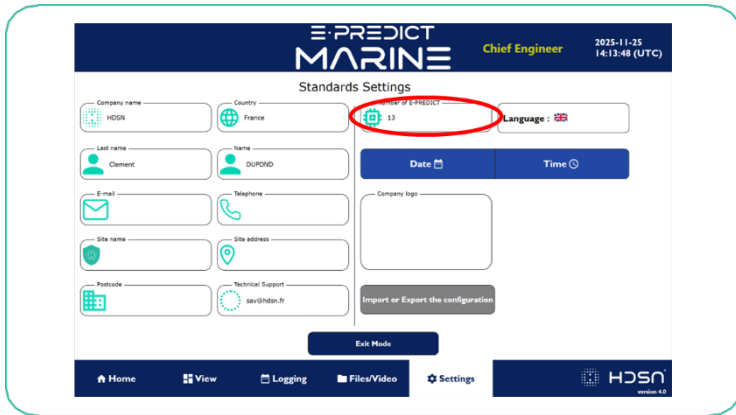

Once an input has been activated, you can modify the activation of an output based on an alarm, alert or product shutdown by clicking on the “configuration” button.

By default :

- output D00 is activated during an alarm.
- output D01 is activated during an alert (sys err).
- output D02 is activated during a product shutdown (sys off).

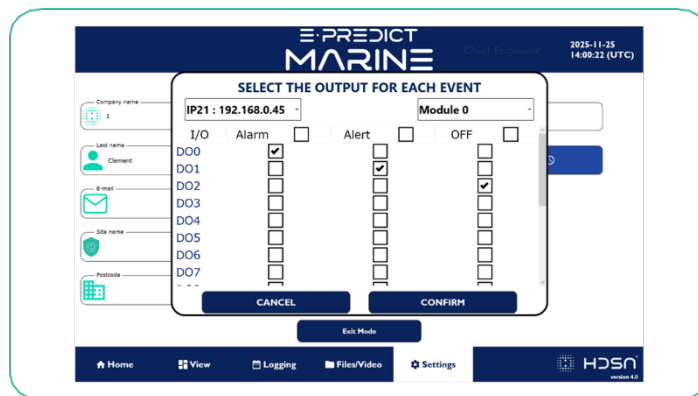

E-PREDICT SUPERVISION CONTROL ACTION V4.0

PERIODIC INSPECTION OF E-PREDICT

If one or more E-PREDICT devices are due for their periodic inspection, follow this procedure:

- Go to the “**SETTINGS**” tab.
- Log in as Chief Engineer / Admin (Password: **112233**).
- Click on the new “**Inspection**” tab, which should appear in red at the bottom right of the screen.



- Once in the “Inspection” tab, select the E-PREDICTs to be tested by clicking on the “**Select E-PREDICT**” button.

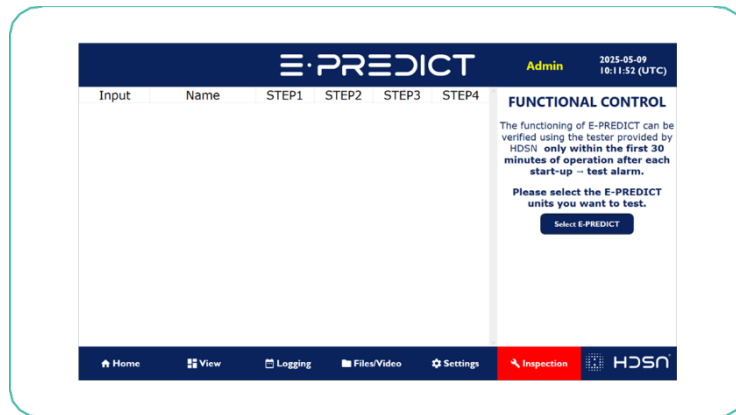

- Once one or more E-PREDICTs have been selected, click on “**Start test**”.

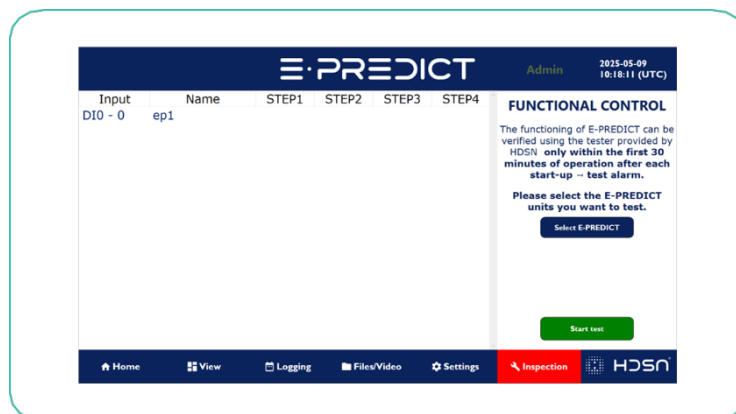

E-PREDICT SUPERVISION CONTROL ACTION V4.0

- **STEP1:** Switch off the E-PREDICT.

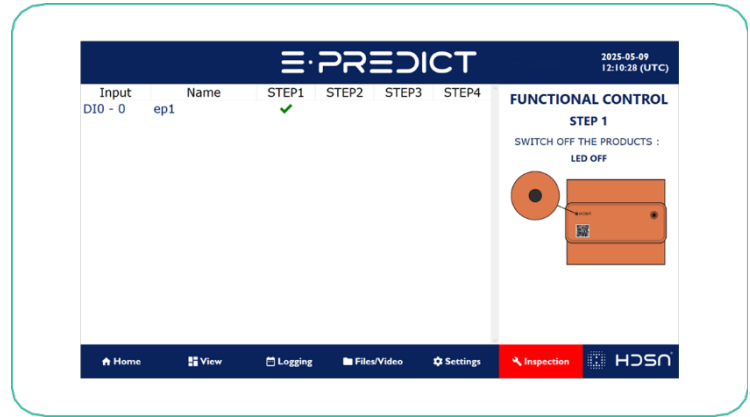
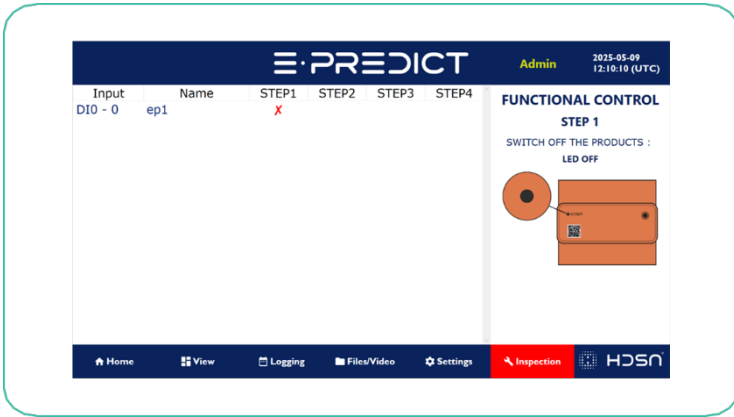

- **STEP2:** Switch on the E-PREDICT.

Note: A 30-minute timer starts as soon as the first E-PREDICT is switched on.

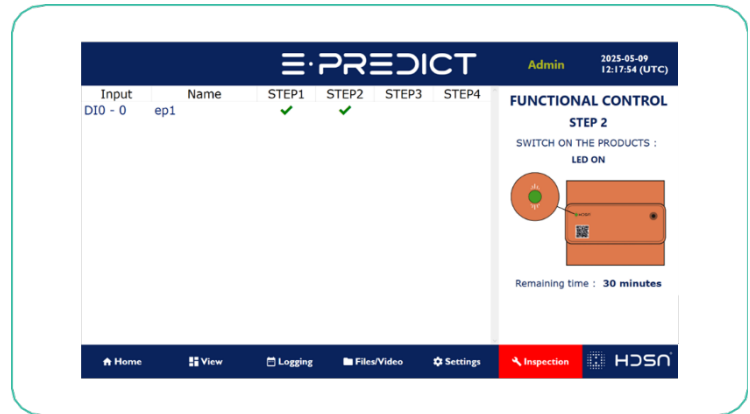
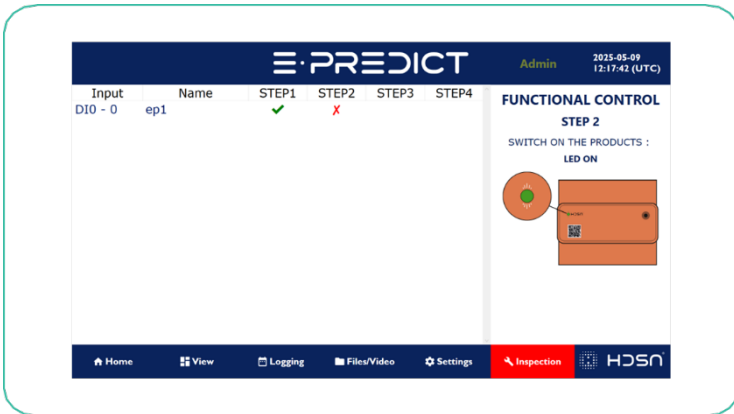

- **STEP3:** Perform the periodic check test following the TechSpec procedure.

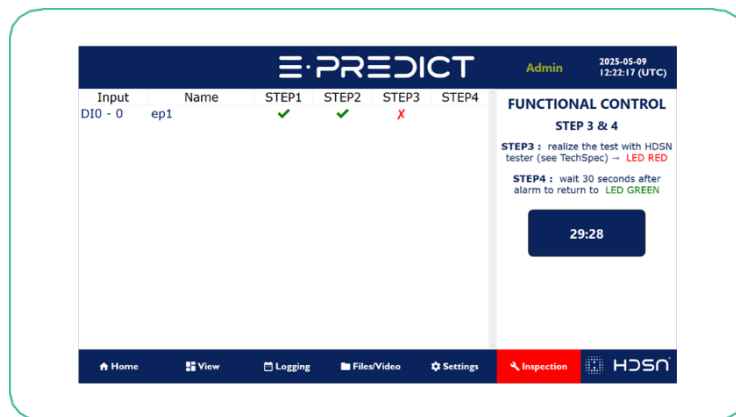

E-PREDICT SUPERVISION CONTROL ACTION V4.0

- **STEP4**: Once all E-PREDICT devices have triggered an alarm and returned to normal. The test is validated.



- The start page (E-PREDICT selection) should reappear. Once this is done, go to the “Logging” tab and check that the validated periodic test log is present for each selected E-PREDICT.

Warning : An E-PREDICT that is not selected during a periodic test and generates an alarm/alert will cause an alarm/alert displayed on the HMI.

E-PREDICT SUPERVISION CONTROL ACTION V4.0

2. MODBUS COMMUNICATION TABLES

This part describes the MODBUS register details. The server's IP address is **10.10.10.1** by default.

Screen IP Client address: 192.168.0.10 (E-PREDICT network reserved for HDSN)

Screen IP Server address: 10.10.10.1 (PLC network)

COIL REGISTERS

Offset	Group	Description
0 to 511	Acknowledge	E-PREDICT ACK
512	Acknowledge	E-PREDICT ACK ALL

HOLDING REGISTERS

Offset	Type	Group	Description
0 to 511	INT	Dry contact	E-PREDICT Status
512	INT	Modules	Number of input backplane
513	INT	Modules	Number of output backplane
514	INT	Alarm	Number of E-PREDICT Alarm
515	INT	Alarm	Number of E-PREDICT in Alert
516	INT	Alarm	Number of E-PREDICT OFF
517	INT	Alarm ACK	Number of E-PREDICT in Alarm ACK
518	INT	Alarm ACK	Number of E-PREDICT in Alert ACK
519	INT	Periodic Test	Number of E-PREDICT in periodic test
520	INT	Inhibited	Number of E-PREDICT Inhibited

E-PREDICT Status				
Disconnected	OFF	OK	Alert	Alarm
0	1	2	3	4
E-PREDICT Status				
Alarm always on E-PREDICT but ACK on HMI	Alert always on E-PREDICT but ACK on HMI	Inhibited	In periodic test	
5	6	7	8	

DISCRETE INPUT

Offset	Group	Description
0-9	Error Network	Backplane Input 1 to 10 Error Network
10-19	Error Network	Backplane Output 1 to 10 Error Network
20-29	Error System	Backplane Input 1 to 10 Error System
30-39	Error System	Backplane Output 1 to 10 Error System
40	System mode	Privilege mode enable

E-PREDICT SUPERVISION CONTROL ACTION V4.0

3. HARDWARE

ODOT CN-8031 ADAPTER

The CN-8031 is a Modbus-TCP network adapter that simultaneously accommodates up to 32 I/O expansion modules. The device can be used as a Daisy Chain. This must be connected via Ethernet to the HMI box.

Power Supply: 24V DC



ODOT CN-8031

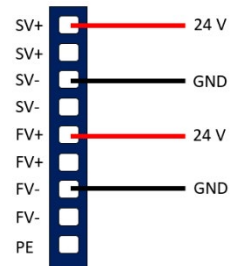

Wiring

CT-121F INPUT MODULE

The CT-121F is a 16-input 24V module that attaches to the ODOT CN-8031. Up to 32 modules can be connected to the ODOT CN-8031. A maximum of 512 inputs can be read.

E-PREDICT must be wired to a module in such a way that:

- The red wire is connected to a DI input.
- The black wire is connected to the 24V.

When an input is powered, an LED lights up to indicate its activation.



CT-121F

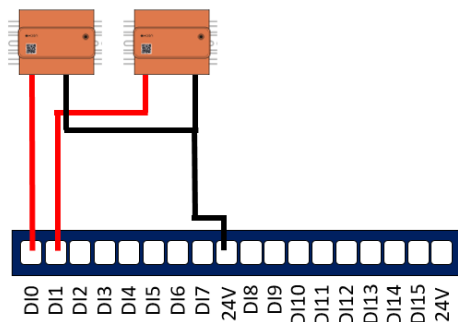

E-PREDICT Wiring

E-PREDICT SUPERVISION CONTROL ACTION V4.0

CT-222F OUTPUT MODULE

The CT-222F is a 16 output 24V module that attaches to the ODOT CN-8031. When an output is powered, an LED lights up to indicate its activation. One of the module's outputs is wired to an alarm device to signal a problem detected by E-PREDICT, whether internal to the system or linked to an external factor.



CT-222F

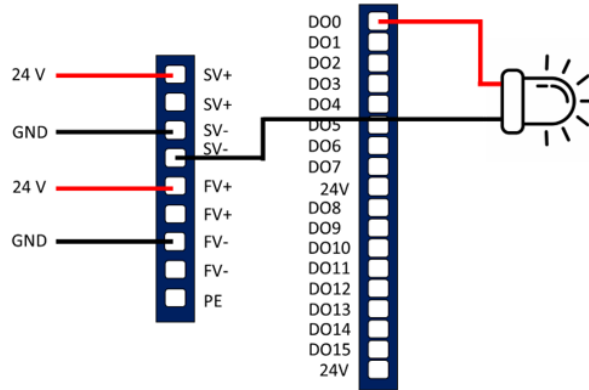

Siren/flash wiring

HMI BOX

The HMI box displays the status of the E-PREDICTs connected to the CN-8031 ODOT and the CT-121F. It consists of a screen and a CT 222F module (connected to an ODOT CN-8031) to power an external device (e.g. a siren) in the event of an alarm.

Power supply: 230V AC



HMI Box

4. MAINTENANCE

CABINET WITH ODOT CN-8031 & CT-121F

Module Replacement Procedure – CT-121F / CT-222F and ODOT CN-8031

If a CT-121F digital inputs module or a CT-222F module becomes non-functional, it must be replaced by an authorized technician and in the exact same physical position on the ODOT CN-8031 communication adapter.

The HMI identifies and communicates with modules based strictly on their physical position.

⚠ Important Warning: Do not shift or rearrange modules after a failure. For example, if Module 1 is defective, do not move Module 2 to position 1 or Module 3 to position 2. All modules must remain in their original assigned positions. Only the defective module should be replaced.

Replacing the ODOT CN-8031 Adapter

If the ODOT CN-8031 adapter itself fails:

- It must be replaced with a new adapter.
- All existing CT-121F modules must be reinstalled in the same order and position on the new adapter.
- The replacement ODOT CN-8031 must be pre-configured by HDSN prior to installation.

Please contact HDSN to obtain a properly configured replacement unit (be@hdsn.fr).

HMI SOFTWARE

Network problem:

If you encounter a problem with a disconnected input or output module, check the RJ45 cables to ensure they are not damaged.

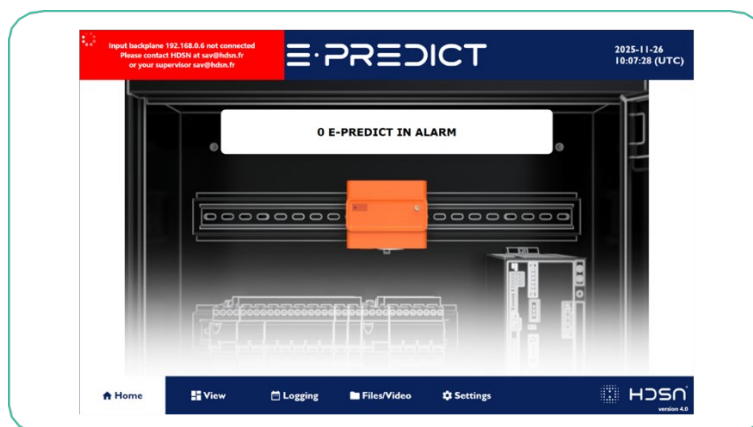

E-PREDICT SUPERVISION CONTROL ACTION V4.0

Module issue:

If you encounter a problem with a damaged module, check that it is properly clipped onto the backplane module (ODOT CN-8031). If not, contact HDSN (sav@hdsn.fr).

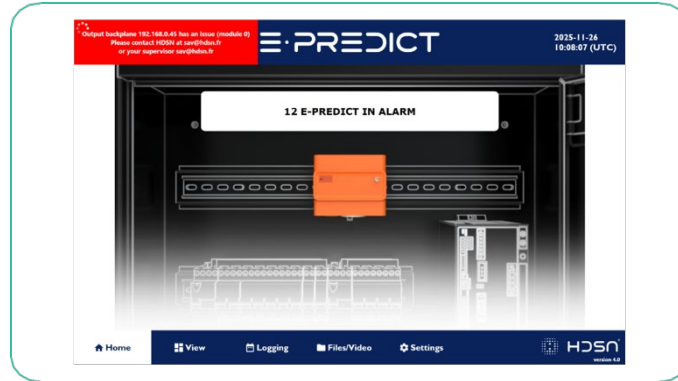

Good



Not Good

if you encounter a problem with the software. Please restart the cabinet (open the cabinet and reset the circuit-breaker inside). If the problem persists, please contact HDSN.

To contact HDSN, please send an email to sav@hdsn.fr

HMI BOX

If any component of the HMI box is no longer working, please contact HDSN.

Please use a backup power supply for the HMI.

